

Pure Sine Wave Inverter Charger

Renogy 1000W | 2000W
Pure Sine Wave Inverter Charger Manual



2775 E. Philadelphia St., Ontario, CA
1-800-330-8678

Version 1.6

Important Safety Instructions

Please save these instructions.

This manual contains important safety, installation, and operating instructions for the inverter. The following symbols are used throughout the manual:

⚠ WARNING: Indicates a potentially dangerous condition. Use extreme caution when performing this task.

CAUTION: Indicates a critical procedure for safe and proper operation of the inverter.

NOTE: Indicates a procedure or function that is important to the safe and proper operation of the inverter.

General Safety Information

- Installation and wiring must comply with the Local and National Electric Codes (NEC) and must be done by a certified technician.
- Read all of the instructions and cautions in the manual before beginning the installation.
- There are no serviceable parts for this inverter. Do **NOT** disassemble or attempt to repair the inverter.
- Make sure all connections going into and from the inverter are tight. There may be sparks when making connections, therefore, make sure there are not flammable materials or gases near installation.

Inverter Safety

- The inverters are suitable for **12V Battery Banks ONLY**.
- **ALWAYS** make sure inverter is in OFF position and disconnect all AC and DC connecting when working on any circuit associated with the inverter.
- **NEVER** connect the AC output of the unit directly to an Electrical Breaker Panel/ Load Centre which is also fed from the utility power / generator.
- When connecting battery terminals, ensure the polarity of the battery connections is correct. Incorrect polarity may cause permanent damage to the unit.
- Be careful when touching bare terminals of capacitors as they may retain high lethal voltages even after power is removed.

Battery Safety

- Do **NOT** let the positive (+) and negative (-) terminals of the battery touch each other.
- Use only sealed lead-acid, flooded, or gel batteries which must be deep cycle.
- Explosive battery gases may be present while charging. Be certain there is enough ventilation to release the gases.
- Be careful when working with large lead acid batteries. Wear eye protection and have fresh water available in case there is contact with the battery acid.
- Over-charging and excessive gas precipitation may damage the battery plates and activate material shedding on them. Too high of an equalizing charge or too long of one may cause damage. Please carefully review the specific requirements of the battery used in the system.

Installation Safety

- The unit should be installed in a well-ventilated, cool, and dry environment. Make sure the fans of the unit and the ventilation holes are not blocked.
- Do not expose the unit to rain, moisture, snow, or liquids of any type.

Table of Contents

General Information.....	5
Included Components	6
Additional Components	6
Identification of Parts (Top View)	8
Identification of Parts (AC Side)	9
Identification of Parts (DC Side)	10
Installation	10
Location Recommendations	11
Sizing a Battery Bank	11
Grounding.....	12
Operation	14
AC Charger.....	14
Inverter Troubleshooting	19
External Fusing	21
Technical Specifications.....	21

General Information

The Renogy Pure Sine Wave Power Inverter Charger delivers superior performance for remote off-grid applications. The inverter is of pure sine wave capable of producing cleaner, smoother, and more reliable electricity for a user's electronic needs. The inverter is also able to charge the battery bank when AC power is connected to the inverter.

Key Features

- Robust and sleek design
- Optimized for 12 VDC system voltage
- DC and AC inputs including GFCI sockets
- Bypass Feature (20A/30A)
- Power Saving Mode
- 4 Stage Battery Charger
- 8 Pre-Set Battery Voltages
- Automatic Generator Start Option
- Peak Efficiency of inverter is 88%
- Multiple electronic protections

Pure Sine Wave

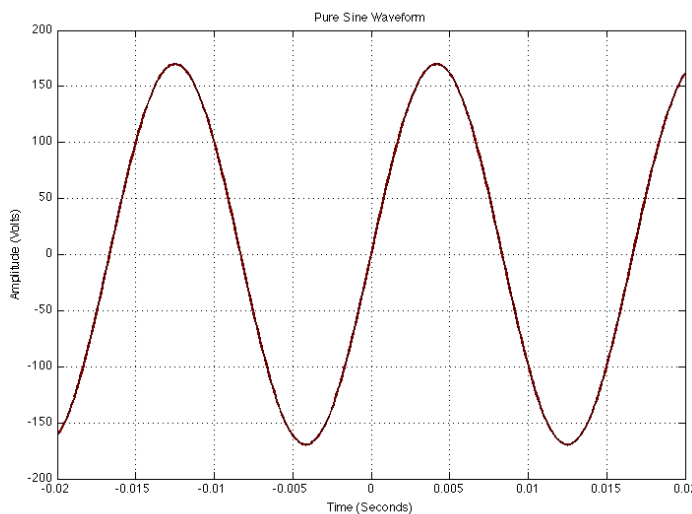

The Renogy Power Inverters output a pure sine wave similar to the waveform of the grid power. In a pure sine wave, the voltage rises and falls in a smooth fashion with very low harmonic distortion and cleaner utility-like power.

This gives users stable enough power to operate tools, fans, lights, computers, and other electronics without any interference. Pure sine wave inverters are in many

cases more efficient, allowing users to use less energy and allow for more device capability. The main advantage to pure sine wave inverters is that they are used to operate sensitive electronic devices that require a high quality waveform with little harmonic distortion. Almost any electronic device could be powered using a pure sine wave inverter.

Included Components

Battery Temperature Sensor (BTS)

Renogy inverter chargers come equipped with a battery temperature sensor that will help prolong the battery life. The temperature sensor allows the charge controller to continuously adjust the charging voltage based on the battery temperature. The charging voltage will be reduced by 0.1V for every degree of temperature above 104°F. The battery temperature sensor should be installed on all battery banks as it ensures that the battery receives the proper voltage. The sensor mounts on the side of the battery.



Condition	Temperature on BTS	Operation
Charger Mode	$BTS \geq 122^{\circ}F$	Charger will turn off
	$BTS \leq 104^{\circ}F$	Charger will turn on
Inverter Mode	$104^{\circ}F \leq BTS \leq 122^{\circ}F$	Low voltage set point decreased by 0.5V
	$BTS \geq 122^{\circ}F$	Over temperature fault

Additional Components

Additional component can be purchased for extra functionality.

LCD Remote Control Module (RCM)

The inverter-chargers feature a remote LCD port for connecting this additional switch panel. It will have the same functionality as the main panel located on the inverter-charger such as “off”, “power saver off”, or “power saver on”. Additionally, the LCD RCM displays input and output AC/DC voltage, output frequency, alarm notifications, and battery status.

When connecting the LCD RCM, it will connect in parallel to the inverter charger’s main switch board. This means to turn the inverter on, both the LCD RCM and the inverter charger switch board need to be in the off position first. Whichever board switches first, will power the inverter charger.

If commands from the two boards conflict with each other, the following priorities will automatically take place:

Power Saver On > Power Saver Off > Power Off

Both panels in the off position will power the inverter off.

NOTE: When the inverter is in Battery-priority mode, finishes a complete charging cycle, and switches to inverter mode, “AC: Abnormal” will be displayed.

NOTE: In AC mode, the LCD will not display the status of the AC load

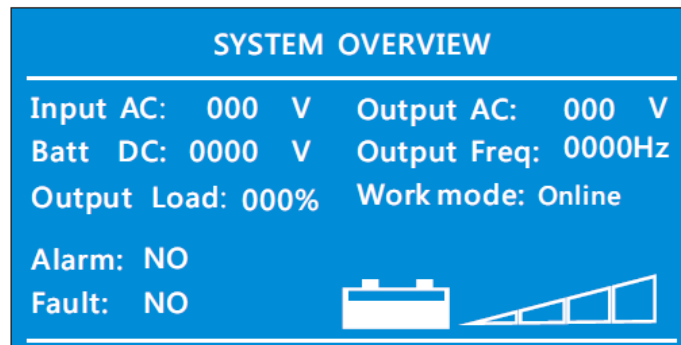
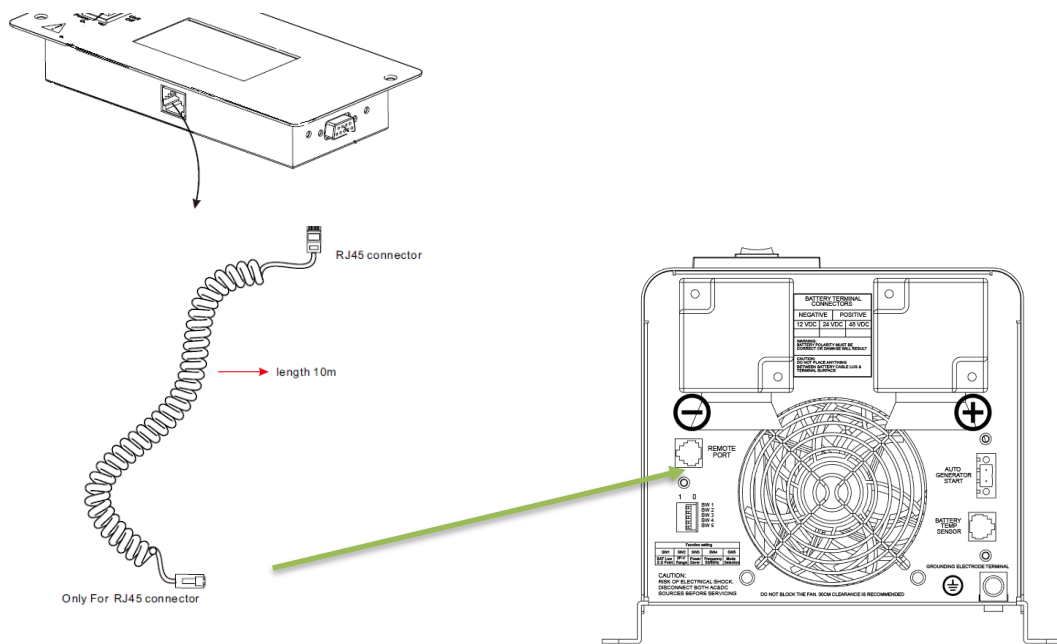

LCD Display

Identification of Parts (Top View)

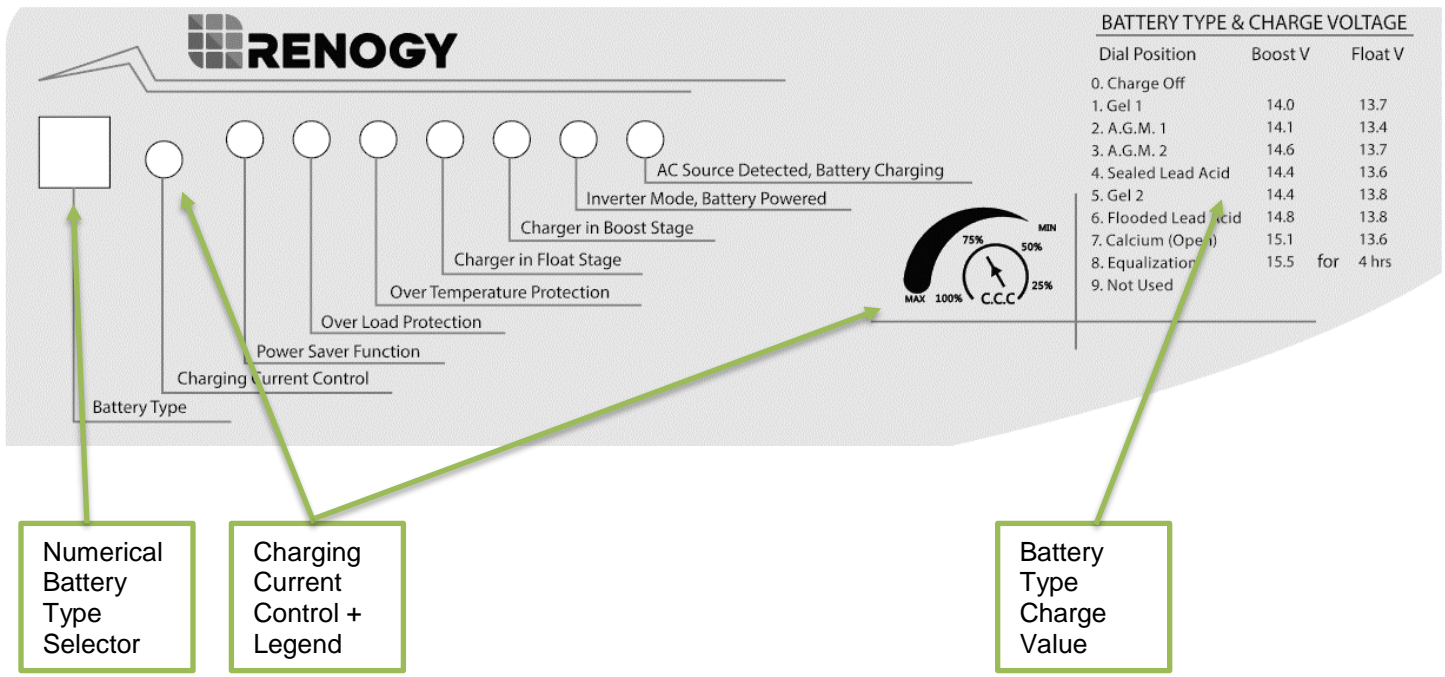
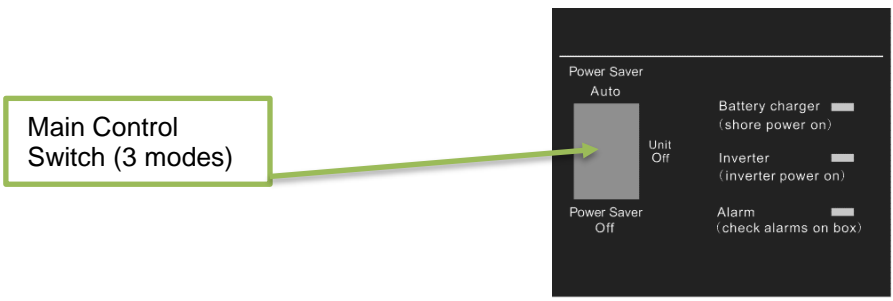
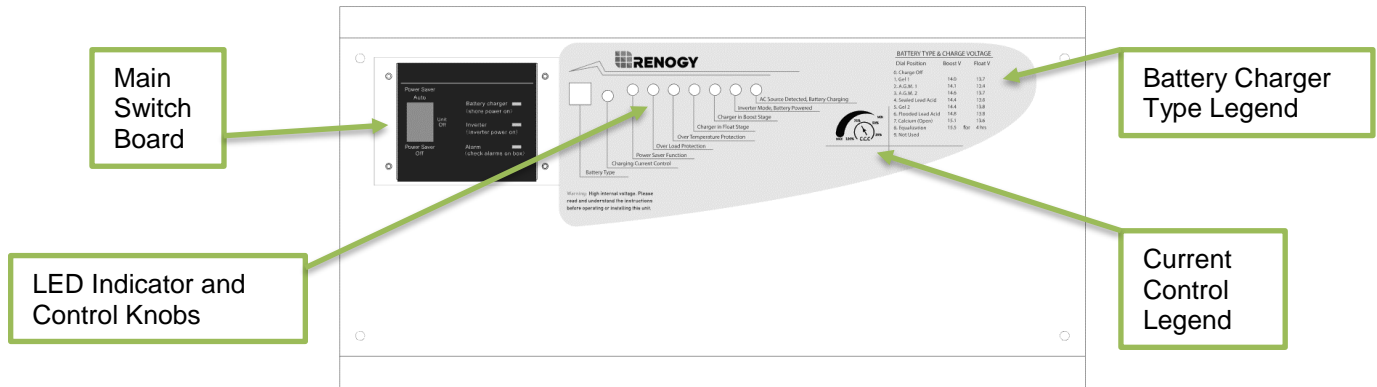

Identification of Parts (AC Side)

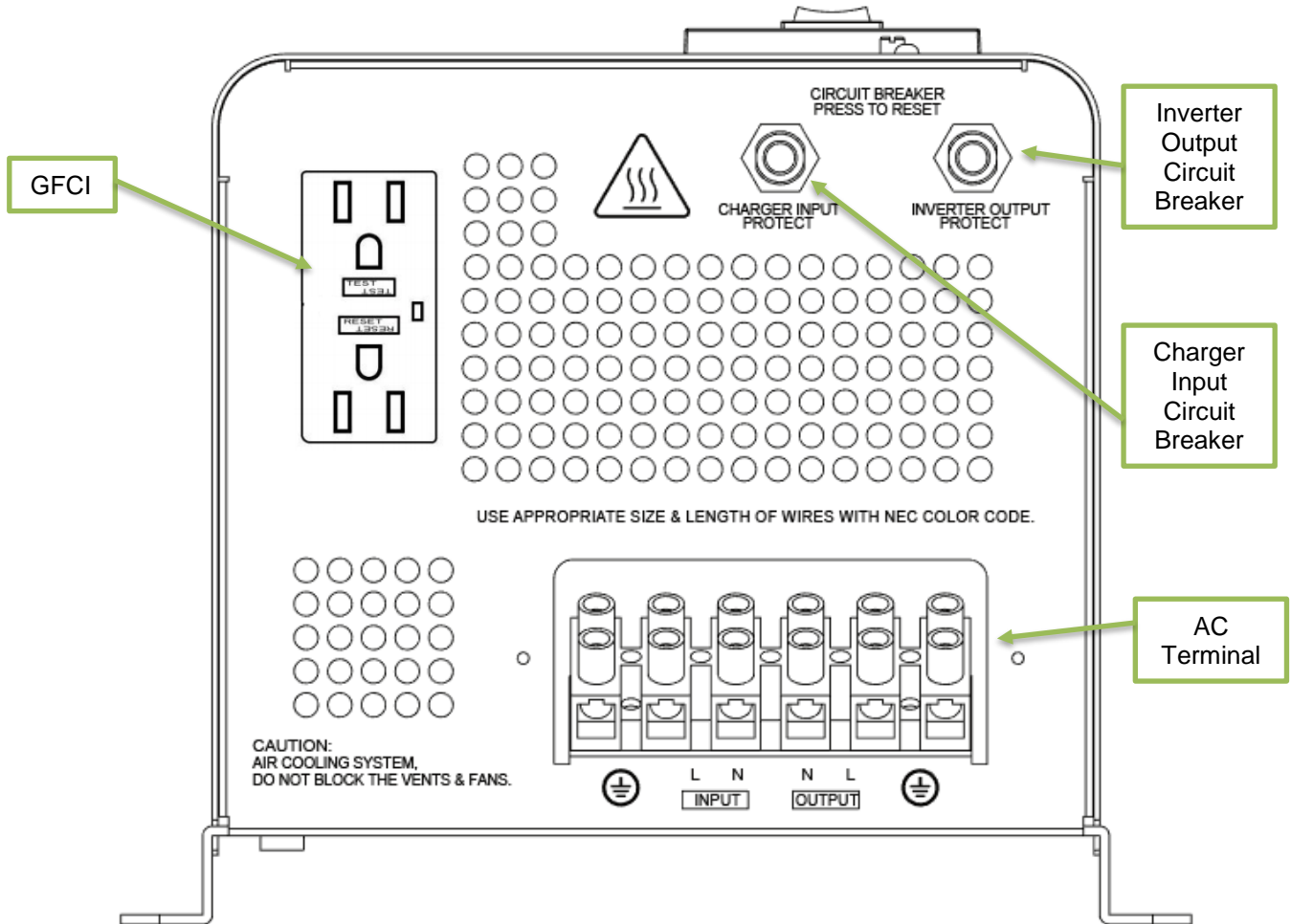

Identification of Parts (DC Side)

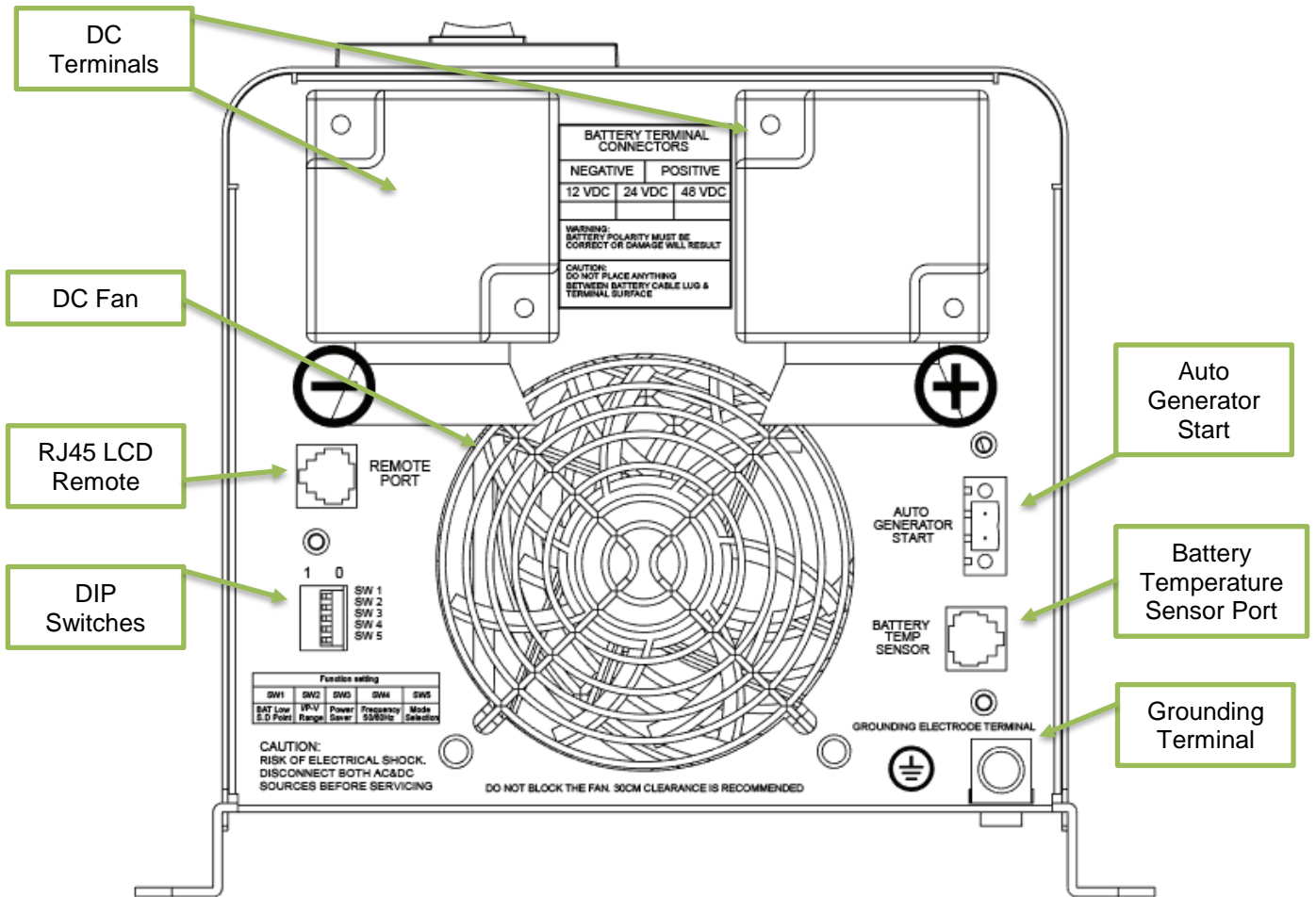

Installation

WARNING: Make sure inverter is in the off position before connecting anything.

CAUTION: Do not over-torque or over tighten the terminals. This could potentially damage the unit

CAUTION: Refer to the technical specifications for max wire sizes on the controller and for the maximum amperage going through wires.

Location Recommendations

WARNING: Never install the inverter in a sealed enclosure with flooded batteries. Gas can accumulate and there is a risk of explosion.

Ensure installation follows the following guidelines:

1. **Cool, dry, well-ventilated area**—Heat is the worst enemy for electronic equipment. Inverters must be in an area where the fans are not blocked or where they are not hit directly by the sun. They should be in an area free of any kind of moisture and allow for clearance of at least 10” around the unit to provide for adequate ventilation.
2. **Protection against fire hazard**—the unit should be away from any flammable material, liquids, or any other combustible material. The unit can spark and the consequences could be severe.
3. **Close proximity to battery bank**—prevent excessive voltage drop by keeping the unit close to the battery bank and having a properly sized wire going from the battery bank to the inverter.
4. **WARNING: Do not install the inverter in the same compartment as the battery bank because it could serve as a potential fire hazard.**
5. **Limiting electromagnetic interference (EMI)**—ensure the inverter is firmly grounded to a building, vehicle, or earth grounded. Keep the inverter away from EMI receptors such as TVs, radios, and other audio/visual electronics to prevent damage/interference to the equipment.
6. **Secure inverter**—the inverter could be stand alone or mounted using the outlying terminals on the inverter.
WARNING: The inverter should never be mounted vertically on a vertical surface since it would present a hazard for the fan opening which is crucial for cooling the inverter.

Sizing a Battery Bank

1. **Determine the amount of Watts (Amps * Volts) for the load, and how long the load needs to operate**—each electrical appliance has a technical specifications indicating the watts, or the volts and amps required for operation.
2. **Estimate load run-time**—determining a battery size relies heavily on load watts and run-times. Most loads will not be constant, so estimations are key.
3. **Utilize the formula Watts = Volts * Amps**
4. **Determine Amps used for how many hours – Amp-hour (Ah)**

***For this Renogy Inverter Charger, the battery bank will be 12 volts direct current (12 VDC)**

Example	
A Microwave = 700 Watts 12V battery bank	700 Watts to run microwave using the batteries as if it was a 12VDC microwave requires 58 Amps $700 \text{ Watts} / 12 \text{ Volts} = 58 \text{ Amps}$
Load Operation = 3 hours	Now that amps have been determined, the amps hours need to be determined. The microwave will be used for approximately 3 hours a day. $58 \text{ Amps} * 3 \text{ hours} = \underline{\mathbf{174 \text{ Ah}}}$
At least a 174 Ah battery must be selected in order to use the 700 Watt microwave at 3 hours a day. However, determining a battery size is also dependent on the battery that is able to handle repeated discharge/charge cycles.	

NOTE: This is just an example. Actual quantities vary by battery capacity and rates of discharge.

NOTE: In the example above, the user would need to be using at least the Renogy 1000W Pure Sine Wave Inverter Charger.

Grounding

The Renogy Pure Sine Wave Inverter Chargers come equipped with a grounding lug for appropriate grounding to earth ground or to another designated ground (For example, a metal frame of an RV). The connections to ground must be tight and against bare metal. Whether using the inverter in a mobile application, such as an RV or in a building, grounding is highly recommended. The recommended wire size for grounding is 8 AWG copper wire. For more information regarding grounding, users and/or installers must consult with the Local and National Electric Codes (NEC) for more specific grounding regulations and suggestions as they can change per scenario.

DC Wiring

CAUTION: We recommend installing the inverter as close as possible to the battery bank. The torque rating for the DC terminal is 12.5NM-20.5NM. The torque rating suggested is 17NM.

Inverter	Cable Size (10 feet distance)
1000W	AWG 4-1/0
2000W	AWG 2/0

AC Wiring

WARNING: AC Output should NEVER be connected to public power or a generator.

CAUTION: When connecting to an AC source we recommend using 6-10AWG wire and wiring just like the picture below. (120V Single Phase Wiring Only). Consult a qualified electrician about specific wire gauge in terms of material and inverter power.

AC Input: Ground-Hot Line-Neutral

AC Output: Neutral-Hot Line-Ground

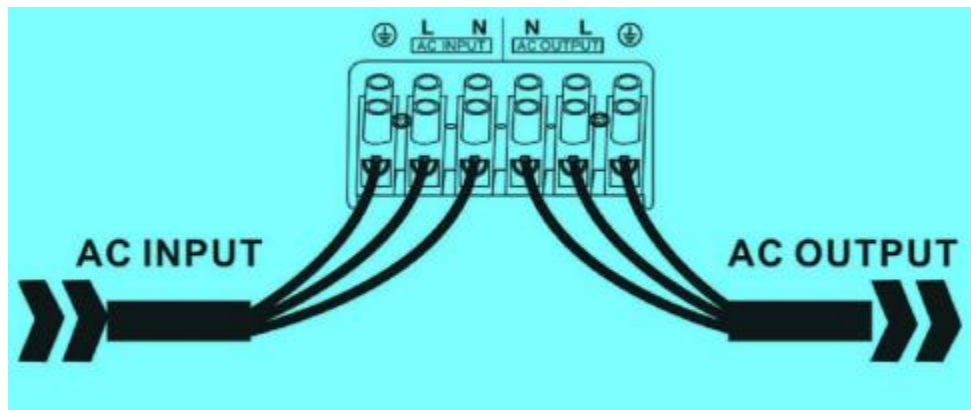

Automatic Neutral-to-Ground Connection

CAUTION: Be careful of the positive and negative poles. Reversing the poles might cause permanent damage to the inverter. It will surely blow the internal fuse.

NOTE: Damage to the Renogy inverters due to reverse polarity is NOT covered by warranty.

NOTE: The input terminals of the inverters have large capacitors connected to them. Once a positive and negative wire are connected to the terminals, it will complete the circuit, and commence drawing a heavy current momentarily. As a result, there may be a sparking occurring even if the inverter is in the off position. To minimize sparking, it is recommended that the user have the appropriate size wire feeding into the inverters and/or install an external fuse leading into the inverter.

The Renogy Inverter Charger is equipped with an automatic neutral-to-ground switch. The inverter uses an internal relay to connect the AC neutral output to the vehicles/boats ground in inverter mode and disconnects it when an external AC source is detected.

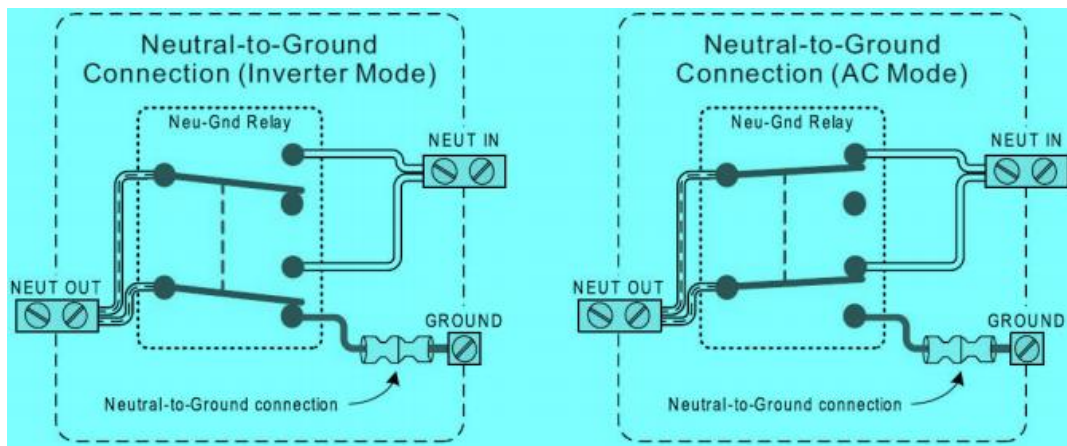

Operation

AC Charger

The Renogy inverter comes equipped with a 4-stage battery charger and an 8-battery type selector switch. The charging current can be adjusted from 25%-100%. The charging current will vary depending on the inverter model.

Switch Position	Description	Boost Voltage	Float Voltage
0	Charger Off	N/A	N/A
1	Gel 1	14.0V	13.7V
2	A.G.M 1	14.1V	13.4V
3	A.G.M 2	14.6V	13.7V
4	Sealed Lead Acid	14.4V	13.6V

5	Gel 2	14.4V	13.8V
6	Flooded Lead Acid	14.8V	13.8V
7	Calcium (Open)	15.1V	13.6V
8	Equalization	15.5V for 4 hrs.	
9	Not Used	N/A	N/A

Battery Charging Stages

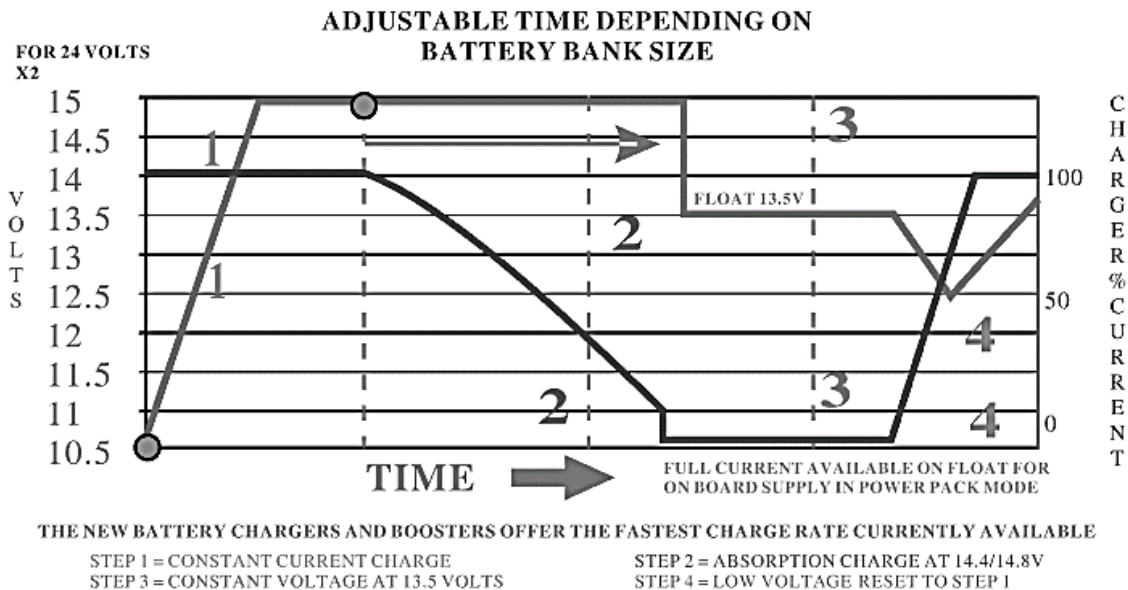

Bulk Stage: The charger will supply constant current until the battery voltage reaches the boost voltage. The software will calculate the time charging began up until the battery voltage reaches 0.3V below the boost voltage. It uses this time to as T_0 and $T_0 \times 10 = T_1$.

Boost Stage: The charger will supply constant voltage and reduce the current slowly through this stage. The charger will stay in this stage until T_1 has run out. After this time the charger will enter the float stage. This stage will last between 1 hour and 12 hours depending on T_1 .

Float Stage: During this stage the charger will supply a constant voltage which is determined by the battery selected and will keep current at a minimum. This stage acts as a trickle charger.

Equalization: This stage is only available if the battery selector is switched to position 8. During this stage the batteries are charged at a higher voltage than normal and for

most batteries this could cause damage. Please refer to the batteries owner's manual or contact the manufacturer to see if this stage is needed.

Transfer Switch

The inverters come with a 20A/30A transfer switch that allows the inverters to switch between AC shore power and AC inverter mode (DC to AC) in a matter of 10 milliseconds. The inverter will automatically switch to battery power when the AC input voltage drops below 90VAC.

DIP Switches

Switch Number	Switch Function	Position: 1	Position: 0
SW 1 (AC Priority)	Low Battery Disconnect	10.5VDC	10.0VDC
SW 1 (Battery Priority)		11.5VDC	10.5VDC
SW 2	AC Input Range	90-130 VAC (40Hz+)	100-130 VAC
SW 3	Power Saver	Detect load every 3s	Inverter Off
SW 4	Frequency Switch	60Hz	50Hz
SW 5	Battery/AC Priority	Battery Priority	AC Priority

SW 1 (Low Battery Disconnect):

This switch can change the low battery disconnect between 10.0V-11.5V. Depending on whether shore power is present or not the low voltage set point will change. For most applications, the voltage should be set to 11.5V to prevent the batteries from being depleted.

SW 2 (AC Input Range):

Most electronics have a recommended AC voltage range and staying within this range will allow the electronic to function normally. Some electronics will function between 100-130VAC 60Hz while other accept a lower frequency 40-60HZ. If the AC source falls below 50Hz or 100VAC then position 1 will need to be used.

SW 3 (Power Saver):

The inverter's power saver mode is activated when position 1 is selected. The inverter will detect a load for 250ms every 3 seconds and if a load is detected the inverter will start outputting AC power. **NOTE:** If the switch position is set to 0 and power saver mode is selected on the inverter main power switch, then no AC power will be outputted unless there is shore power connected to the inverter.

SW 4 (Frequency Switch):

The inverter can be set to output 50Hz or 60Hz using this switch

SW 5 (Battery/AC Priority):

When the inverter is set to battery priority (Position 1) it will invert power from the battery bank to the AC outlets until the low voltage set point is reached. If there is an AC source connected while under battery priority it will charge the battery after the low voltage is reached and use the AC source to power the AC outlets. When the battery is fully charged, the inverter will switch to battery power.

When choosing AC priority (Position 0) the battery power will only be used when there is no shore power connected to the inverter. Once AC power is connected the inverter will start charging the battery bank. If shore power is present for 15 continuous days, then the inverter will use the battery bank for one cycle. This cycle is used to prolong battery life.

LED Modes

Status	Function	Power Saver	Over Load	Over Temp	Float Charge	Fast Charge	Inverter Mode	Shore Power
Charge Function	Constant Current Charge	-	-	-	-	On	-	On
	Constant Voltage Charge	-	-	-	-	Blinking	-	On
	Float Charge	-	-	-	On	-	-	On
	Stand By	-	-	-	-	-	-	On
Inverter Mode	Inverter On	-	-	-	-	-	-	On
	Power Saver on	On		-	-	-	-	-

Power Saver Mode

The Renogy Inverter Charger has two working mode: “Power Saver Off” and “Power Saver AUTO”

When the inverter is switched on to Power Saver Off the inverter will supply AC power without any interruptions.

When the inverter is switched on to Power Saver AUTO the inverter will send a signal to the AC loads for 250ms every 3 seconds and if an AC device (50W+) is connected the

inverter will start supplying power. **NOTE:** To activate this mode DIP switch 3 must be set to position 1.

The idle consumption when using power saver mode is approximately 8 watts.

Audible Alarm

Indicator	Behavior
Over Temperature	Heat sink temperature $\geq 221^{\circ}\text{F}$ (Over Temperature LED light on) beeps every second
Low Battery Voltage	Inverter LED (Green) on and beeps every second
High Battery Voltage	Inverter LED (Green) on and beeps every 5 seconds
Inverter Over-Load	Load $>110\%$ beeps every second

Fan Operation

Condition	Enter Condition	Leave Condition	Fan Speed
Temperature	$149^{\circ}\text{F} \leq T < 185^{\circ}\text{F}$	$T \leq 140^{\circ}\text{F}$ or $T \geq 185^{\circ}\text{F}$	50%
	$T > 185^{\circ}\text{F}$	$T \leq 176^{\circ}\text{F}$	100%
Charging Current	$20\% < I \leq 50\% \text{Max}$	$I \leq 15\%$ or $I > 50\% \text{Max}$	50%
	$I > 50\% \text{Max}$	$I \leq 40\% \text{Max}$	100%
AC Load	$30\% \leq \text{Load} < 50\%$	Load $\leq 20\%$ or Load $\geq 50\%$	50%
	Load $\geq 50\%$	Load $\leq 40\%$	100%

Please allow a minimum of 6 inches of clearance around the inverter's vents. Fan noise level $<60\text{db}$ at 1 meter.

Auto Gen Start

The Renogy Inverter Charger can start up a generator when the low battery voltage set point is reached. The auto gen start feature will only work with generators compatible with this feature.

Inverter Troubleshooting

The following table will help identify the inverters failure. Use the LED lights and compare with the following graph.

Status	Fault	Power Saver	Over-Load	Over Temp	Charger in Float Stage	Charger in Boost Stage	Inverter Mode	AC Source	Alarm
Inverter Mode	Low Bat Volt	Off	Off	Off	Off	Off	Green LED on	Off	Beep every 5 secs
	High Bat Volt	Off	Off	Off	Off	Off	Green LED on	Off	Beep every second
	Over-Load	Off	Red LED on	Off	Off	Off	Green LED on	Off	Beep every second
	Over-Temp	Off	Off	Red LED on	Off	Off	Green LED on	Off	Beep every second
	Over-Temp (AC Source)	Off	Off	Red LED on	Off	Yellow LED on	Off	Green LED on	Beep every second
	Over Charge	Off	Off	Off	Off	Yellow LED on	Off	Green LED on	Beep every second
AC Mode	Fan Lock	Off	Off	Off	Off	Off	Off	Off	Beep cont.
	Inverter Over-load	Off	Red LED on	Off	Off	Off	Off	Off	Beep cont.
	Output Short	Off	Red LED on	Off	Off	Off	Off	Off	Beep cont.
	Back Feed Short	Off	Off	Off	Off	Off	Off	Off	Beep cont.

Indicator	Troubleshoot
Under Voltage Alarm	Use a multi-meter to check the voltage of the battery. Make sure the battery voltage is not below the rated specification of the inverter. The inverters have an input requirement of at least 10.5 ± 0.5 volts. Disconnect battery if necessary.
Over Voltage Alarm	Use a multi-meter to check the voltage of the battery. Make sure the battery voltage is not exceeding the rated specification of the inverter. The maximum input voltage should not be exceeding 16 volts.
Over Load Protection	Turn off the inverter and check the rated specification for the electronic device(s). Be sure to check that the watts (volts * amps) does not exceed the specification for the inverter. Be very cautious if using power strips as they can be clear indicator for overload for inverters. Also, some electronic devices may require an initial high power surge start. Make sure all AC appliances are off before turning on the inverter's power switch.
Short Circuit	A short might occur down the DC line connecting to the inverter. Check the battery connections going to the inverter and ensure that there is continuity. If there is an in-line fuse installed, check to make sure the fuse has not blown. Reset the inverter by turning it off for approximately 5 seconds and powering it back on.
Other Considerations	
Battery cables are connected to the inverter but it does not power on	The inverter needs a minimum of 10.5 volts to operate. Use a multi-meter to make sure the battery levels are suitable for operation. If all checks out, check the wire connections and inspect for any breaks or tears.
There is no AC output or LED indicator lights on	Make sure the inverter is switched to Power saver on or Power saver off.
The battery charger turns off while connected to an external AC source	The AC input voltage is not within the acceptable range.
Idle draw from inverter	When the inverter is switched on, the circuitry inside is activated. Even if there is no load on the AC side of the inverter, users will experience a small amount of current draw to keep the circuitry within the inverter ready to power. It is recommended to turn off the inverter when not in use.
The inverter is only able to run AC loads for a short period of time	This will happen when the battery voltage is low. Check battery voltage and resume running loads when battery voltage is above 12.7 volts.

External Fusing

Fusing is a recommended in PV systems to provide a safety measure for connections going from panel to controller and controller to battery. Remember to always use the recommended wire gauge size based on the PV system and the controller.

NEC Maximum Current for different Copper Wire Sizes									
#AWG	16	14	12	10	8	6	4	2	0
Max. Current	10A	15A	20A	30A	55A	75A	95A	130A	170A

Technical Specifications

Model	RNG-INVT-1000-12V-C	RNG-INVT-2000-12V-C
Rated Power	1000W	2000W
Surge Power	2000W	4000W
Rated Voltage	12V	
Rated Voltage Range	10V-16V	
Input Voltage	DC $\geq 10V \pm 0.5V$	
Over-Voltage Range	16V $\pm 0.5V$	
Low Battery Voltage Alarm	10.5V/11.0V	
Output Waveform	Pure Sine Wave	
Nominal Efficiency	$>88\%$ Peak	
Power Factor	0.9-1.0	
Battery Charging Current	5-25 A	15-45 A
Idle Power Consumption	2.5 A, 3 A (Fan On)	4 A, 4.5 A (Fan On)
Nominal Output Voltage	100-110-120VAC	
Output Voltage Regulation	$\pm 10\%$ RMS	
Output Frequency	50/60Hz $\pm 0.3\text{Hz}$	
THD	$<10\%$	
Input Voltage Waveform	Sine Wave (External AC Source)	

AC Input Range	90-135 VAC	
AC Input Frequency Range	57-65±0.3Hz for 60Hz	
Low Voltage Disconnect	80V/90V±4%	
Low Voltage Reconnect	90V/100V±4%	
High Voltage Disconnect	140V±4%	
High Voltage Reconnect	135V±4%	
Short Circuit Protection (AC Output)	Circuit Breaker	
Bypass Breaker Rating	20A	30A
Dimension	15 x 8.5 x 7 in 381 x 215.9 x 177.8 mm	20.5 x 8.5 x 7 in 520.7 x 215.9 x 177.8 mm
Weight	35.27 lbs.	40.9 lbs.
Operating Temperature	14°F-122°F	
AC Sockets	2	4

Charging Parameters

Number	Battery Type	Boost Voltage	Float Voltage
1	Gel 1	14.0V	13.7V
2	A.G.M 1	14.1V	13.4V
3	A.G.M 2	14.6V	13.7V
4	Sealed Lead Acid	14.4V	13.6V
5	Gel 2	14.4V	13.8V
6	Flooded Lead Acid	14.8V	13.8V
7	Calcium (Open)	15.1V	13.6V
8	Equalization	15.5V for 4 hrs.	

Renogy reserves the right to change the contents of this manual without notice.